

Data sheet

Pressure reduction controller (PN 16, 25, 40)

AFD / VFG 2(1) - for water

AFD / VFGS 2 - for steam

Description



The controller has a control valve, an actuator with one control diaphragm and a spring for pressure setting.

Further on three valve versions are available:

- VFG 2 for water, with metallic sealing cone
- VFG 21 for water, with soft sealing cone
- VFGS 2 for steam, with metallic sealing cone

Main data:

- DN 15-250
- k_{vs} 4,0-400 m³/h
- PN 16, 25, 40
- Setting range:
0,05-0,35 bar / 0,15-1,5 bar / 0,1-0,7 bar /
0,5-3 bar / 1-6 bar / 3-12 bar / 8-16 bar
- Temperature:
- VFG - Circulation water / glycolic water up to
30 %: 2 ... 140 / 150 / 200 °C
- VFGS - Steam / circulation water / glycolic
water up to 30 %: 2...200/300/350
- Connections:
- Flange

The controller is a self-acting pressure reduction controller primarily for use in district heating systems. The controller is normally open and closes on rising differential pressure.

Ordering

Example 1:
Pressure reduction controller; for water; DN 15; k_{vs} 4,0; PN 16; metallic sealing; setting range 0,15-1,5 bar; T_{max} 150 °C; flange;

- 1x VFG 2 DN 15 valve
Code no: **065B2388**
- 1x AFD actuator
Code no: **003G1005**
- 1x Impulse tube set AF
Code no: **003G1391**

Products will be delivered separately.

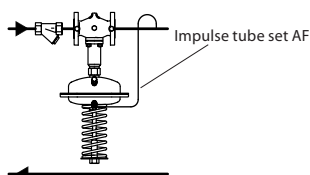

VFG 2 Valves (metallic sealing cone) - for water

| Picture | DN (mm) | k_{vs} (m ³ /h) | T_{max} (°C) | | Connections | Code No. | | |
|---------|-------------------|---------------------------------|-------------------|-------------------|------------------------------|-----------------|-----------------|-----------------|
| | | | | | | PN 16 | PN 25 | PN 40 |
| | 15 | 4,0 | 150 | 200 ¹⁾ | Flanges acc. to EN 1092-1 | 065B2388 | 065B2401 | 065B2411 |
| | 20 | 6,3 | | | | 065B2389 | 065B2402 | 065B2412 |
| | 25 | 8,0 | | | | 065B2390 | 065B2403 | 065B2413 |
| | 32 | 16 | | | | 065B2391 | 065B2404 | 065B2414 |
| | 40 | 20 | | | | 065B2392 | 065B2405 | 065B2415 |
| | 50 | 32 | | | | 065B2393 | 065B2406 | 065B2416 |
| | 65 | 50 | | | | 065B2394 | 065B2407 | 065B2417 |
| | 80 | 80 | | | | 065B2395 | 065B2408 | 065B2418 |
| | 100 | 125 | | | | 065B2396 | 065B2409 | 065B2419 |
| | 125 | 160 | 140 | 200 ¹⁾ | Flanges acc. to EN 1092-1 | 065B2397 | 065B2410 | 065B2420 |
| | 150 | 280 | | | | 065B2398 | | 065B2421 |
| | 200 | 320 | | | | 065B2399 | - | 065B2422 |
| | 250 | 400 | 200 ¹⁾ | 200 ¹⁾ | Flanges acc. to EN 1092-1 | 065B2400 | | 065B2423 |
| | 150 ²⁾ | 280 | | | | 065B2424 | | |
| | 200 ²⁾ | 320 | | | | 065B2425 | | |
| | 250 ²⁾ | 400 | | | | 065B2426 | | |

Note: other valves available on special request.

¹⁾ at temperatures above 150 °C (DN 15-125)/140 °C (DN 150-250) only with seal pots (see Accessories)

²⁾ Valve has valve body extension (VBE)

Ordering (continuous)

Example 2:
Pressure reduction controller; for water; DN 15; k_{vs} 4,0; PN 16; metallic sealing; setting range 0,15-1,5 bar; T_{max} 200 °C; flange;

- 1x VFG 2 DN 15 valve
Code no: **065B2388**
- 1x AFD actuator
Code no: **003G1005**
- 1x Impulse tube set AF
Code no: **003G1391**
- 1x Seal pot V1
Code no: **003G1392**

Products will be delivered separately.

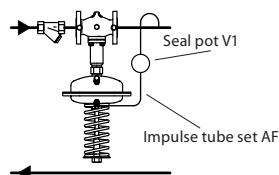

Example 3:
Pressure reduction controller; for steam; DN 15; k_{vs} 4,0; PN 16; metallic sealing; setting range 0,15-1,5 bar; T_{max} 350 °C; flange;

- 1x VFGS 2 DN 15 valve
Code no: **065B2430**
- 1x AFD actuator
Code no: **003G1005**
- 1x Impulse tube set AF
Code no: **003G1391**
- 1x Seal pot V1
Code no: **003G1392**
- 1x Stem extension ZF4
Code no: **003G1394**

Products will be delivered separately.

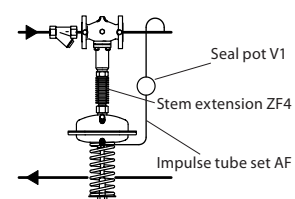

VFG 21 Valves (soft sealing cone) - for water

| Picture | DN (mm) | k_{vs} (m³/h) | T_{max} (°C) | Connections | Code No. |
|---------|------------|--------------------|-------------------|---------------------------|-----------------|
| | | | | | PN 16 |
| | 15 | 4,0 | 150 | Flanges acc. to EN 1092-1 | 065B2502 |
| | 20 | 6,3 | | | 065B2503 |
| | 25 | 8,0 | | | 065B2504 |
| | 32 | 16 | | | 065B2505 |
| | 40 | 20 | | | 065B2506 |
| | 50 | 32 | | | 065B2507 |
| | 65 | 50 | | | 065B2508 |
| | 80 | 80 | | | 065B2509 |
| | 100 | 125 | | | 065B2510 |
| | 125 | 160 | | | 065B2511 |
| | 150 | 280 | 140 | | 065B2512 |
| | 200 | 320 | | | 065B2513 |
| | 250 | 400 | | | 065B2514 |

Note: other valves available on special request.

VFGS 2 Valves (metallic sealing cone) - for steam

| Picture | DN (mm) | k_{vs} (m³/h) | $k_{vs}^{1)}$ (m³/h) | $T_{max}^{2)}$ (°C) | Code No. | | | |
|-------------------|------------|--------------------|-------------------------|------------------------|-----------------|-----------------|-----------------|-----------------|
| | | | | | PN 16 | PN 25 | PN 40 | |
| | 15 | 4,0 | 2,5 | 350 | 065B2430 | 065B2443 | 065B2453 | |
| | 20 | 6,3 | 4,0 | 350 | 065B2431 | 065B2444 | 065B2454 | |
| | 25 | 8,0 | 6,3 | 350 | 065B2432 | 065B2445 | 065B2455 | |
| | 32 | 16 | 10 | 350 | 065B2433 | 065B2446 | 065B2456 | |
| | 40 | 20 | 16 | 350 | 065B2434 | 065B2447 | 065B2457 | |
| | 50 | 32 | 25 | 350 | 065B2435 | 065B2448 | 065B2458 | |
| | 65 | 50 | 40 | 350 | 065B2436 | 065B2449 | 065B2459 | |
| | 80 | 80 | 63 | 350 | 065B2437 | 065B2450 | 065B2460 | |
| | 100 | 125 | 100 | 350 | 065B2438 | 065B2451 | 065B2461 | |
| | 125 | 160 | 125 | 350 | 065B2439 | 065B2452 | 065B2462 | |
| | | 150 ³⁾ | 280 | - | 300 | 065B2440 | - | 065B2463 |
| | | 200 ³⁾ | 320 | - | 300 | 065B2441 | - | 065B2464 |
| 250 ³⁾ | | 400 | - | 300 | 065B2442 | - | 065B2465 | |

¹⁾ Valves with built in flow divider for noise reduction (see accessories)

²⁾ Max. medium temperatures for valves VFGS 2 (in steam applications always accessories have to be used - see table below)

³⁾ Valve has valve body extension (VBE)

Max. medium temperatures and use of accessories

| Steam temp. | PN16 | | PN25 | | PN40 | |
|----------------|-----------|------------|-----------|------------|-----------|------------|
| | DN 15-125 | DN 150-250 | DN 15-125 | DN 150-250 | DN 15-125 | DN 150-250 |
| up to 200 °C | SP | SP + VBE | SP | | SP | SP + VBE |
| 200 ... 300 °C | SP + ZFx | SP + VBE | SP + ZFx | | SP + ZFx | SP + VBE |
| 300 ... 350 °C | | | SP + ZFx | | SP + ZFx | |

Remark - following accessories have to be used as stated in table above:

- SP - Seal pot
 - ZF - Stem extension
 - VBE - Valve with valve body extension
 - - Valve is not to be used
- See Accessories

Ordering (continuous)
AFD Actuators

| Picture | Pressure setpoint (bar) | For DN | Code No. |
|---------|-------------------------|------------|----------|
| | 8-16 | DN 15-125 | 003G1000 |
| | 3-12 | | 003G1001 |
| | 1-6 | DN 150-250 | 003G1413 |
| | 1-6 | DN 15-125 | 003G1002 |
| | 0,5-3 | | 003G1003 |
| | 0,15-1,5 | DN 15-250 | 003G1005 |
| | 0,1-0,7 | | 003G1004 |
| | 0,05-0,35 | | 003G1006 |

Accessories

| Picture | Type designation | Description | Connections | Code No. |
|---------|--|--|----------------|----------|
| | Impulse tube set AF | - 1x Copper tube Ø10 x 1 x 1500 mm - 1 x compression fitting for imp. tube connection to pipe (G ¼) - 2 x socket | - | 003G1391 |
| | Seal pot V1 ¹⁾ | Capacity 1 litre; with compression fittings for imp. tube Ø10 | - | 003G1392 |
| | Seal pot V2 ¹⁾ | Capacity 3 litre; with compression fittings for imp. tube Ø10, for actuator size 630 cm ² | - | 003G1403 |
| | Compression fitting ²⁾ | For impulse tube Ø10 connections to controller | G ¼ | 003G1468 |
| | Combination piece KF3 | For combination with pressure and electrical actuators | G 1¼ / 2x G 1¼ | 003G1397 |
| | Combination piece KF2 | For combination with thermostat | | 003G1398 |
| | Shut off valve | For impulse tube Ø10 | - | 003G1401 |
| | Throttle valve | | | 065B2909 |
| | Flow dividers for VFGS 2 ³⁾ | Flowdivider DN 15, 20 | - | 065B2775 |
| | | Flowdivider DN 25, 32 | | 065B2776 |
| | | Flowdivider DN 40, 50 | | 065B2777 |
| | | Flowdivider DN 65, 80 | | 065B2778 |
| | | Flowdivider DN 100, 125 | | 065B2779 |

¹⁾ Seal pot has to be used on impulse tubes when $T_{max} \geq 200$ °C and always in steam applications

²⁾ Consist of a nipple, compression ring and nut

³⁾ Flowdividers can be used in steam application for noise reduction ; after instaling into the valve, valve's kvs is reduced - see VFGS 2 table

Accessories – Stem extensions ¹⁾



| Picture | Type | For valves DN | T _{max} (°C) | Medium | | Used for sealing | Used for isolation | Code No. |
|---------|------|---------------|-----------------------|--------|-------------------|------------------|--------------------|----------|
| | | | | water | steam | | | |
| | ZF4 | 150-250 | 300 | Yes | Yes ²⁾ | Yes | Yes | 003G1429 |
| | ZF4 | 15-125 | 350 | | Yes | | | 003G1394 |
| | ZF5 | | 350 | | Yes | | | 003G1396 |
| | ZF6 | | 200 | | Yes ²⁾ | | - ³⁾ | 003G1393 |
| | D40 | | 200 | | | | Yes | 065B2986 |

¹⁾ Stem extension has to be used always when $T_{max} > 200$ °C

²⁾ Condensate

³⁾ ZF6 can be used for stroke position indication

Ordering (continuous)
Service kits

| Picture | Type designation | DN (mm) | k _{VS} (m ³ /h) | Code No. | | |
|---|-----------------------------------|-----------------|--|-----------------|-----------------|-----------------|
| | | | | for VFG 2 | for VFG 21 | for VFGS 2 |
|  | Valve insert | 15 | 4,0 | 065B2796 | 065B2790 | 065B2802 |
| | | 20 | 6,3 | 065B2797 | 065B2791 | 065B2803 |
| | | 25 | 8 | 065B2798 | 065B2792 | 065B2804 |
| | | 32 | 16 | | | |
| | | 40 | 20 | 065B2799 | 065B2793 | 065B2805 |
| | | 50 | 32 | | | |
| | | 65 | 50 | 065B2800 | 065B2894 | 065B2806 |
| | | 80 | 80 | | | |
| | | 100 | 125 | 065B2801 | 065B2895 | 065B2807 |
| | | 125 | 160 | | | |
| | | 150 | 280 | 065B2964 | 065B2966 | - |
| 250 | 400 | 065B2965 | - | - | | |
|  | Stuffing cone (with EPDM O-rings) | | | | 003G1464 | |

Technical data
Valves

| Nominal diameter | | DN | 15 | 20 | 25 | 32 | 40 | 50 | 65 | 80 | 100 | 125 | 150 | 200 | 250 | |
|--|----------------------|---|-------------------------------------|-----|-----|------|------|-----|-----|------|-----|-------------------------------------|----------------------------------|-----|-----|--|
| k _{VS} value | m ³ /h | | 4,0 | 6,3 | 8,0 | 16 | 20 | 32 | 50 | 80 | 125 | 160 | 280 | 320 | 400 | |
| k _{VS} value ¹⁾ | | | 2,5 | 4,0 | 6,3 | 10 | 16 | 25 | 40 | 63 | 100 | 125 | - | - | - | |
| Cavitation factor z | | | 0,6 | 0,6 | 0,6 | 0,55 | 0,55 | 0,5 | 0,5 | 0,45 | 0,4 | 0,35 | 0,3 | 0,2 | 0,2 | |
| Leakage acc. to standard IEC 534 (% of k _{VS}) | VFG 2 | ≤ 0,03 | | | | | | | | | | | ≤ 0,05 | | | |
| | VFG 21 | ≤ 0,01 | | | | | | | | | | | | | | |
| | VFGS 2 | ≤ 0,03 | | | | | | | | | | | ≤ 0,05 | | | |
| Nominal pressure | | PN | 16, 25, 40 | | | | | | | | | | | | | |
| Max. differential pressure | PN 16 | bar | 16 | | | | | | | 15 | 12 | 10 | | | | |
| | PN 25, 40 | | 20 | | | | | | | | | | | | | |
| Medium | VFG 2, VFG 21 | Circulation water / glycolic water up to 30 % | | | | | | | | | | | | | | |
| | VFGS 2 | Steam /circulation water / glycolic water up to 30% | | | | | | | | | | | | | | |
| Medium pH | | Min. 7, max. 10 | | | | | | | | | | | | | | |
| Medium temperature | VFG 2 | °C | 2 ... 150 / 2 ... 200 ²⁾ | | | | | | | | | 2 ... 140 / 2 ... 200 ²⁾ | | | | |
| | VFG 21 | | 2 ... 150 | | | | | | | | | 2 ... 140 | | | | |
| | VFGS 2 ³⁾ | | 2...200 / 2...300 / 2...350 | | | | | | | | | 2 ... 300 | | | | |
| Connections | | Flange | | | | | | | | | | | | | | |
| Materials | | | | | | | | | | | | | | | | |
| Valve body | PN 16 | Grey cast iron EN-GJL-250 (GG-25) | | | | | | | | | | | | | | |
| | PN 25 | Ductile iron EN-GJS-400(GGG-40.3) | | | | | | | | | | | | | | |
| | PN 40 | Cast steel GP240GH (GS-C 25) | | | | | | | | | | | | | | |
| Valve seat | | Stainless steel, mat. No. 1.4021 | | | | | | | | | | | Stainless steel, mat. No. 1.4313 | | | |
| Valve cone | | Stainless steel, mat. No. 1.4404 | | | | | | | | | | | Stainless steel, mat. No. 1.4021 | | | |
| Sealing | VFG 2, VFGS 2 | Metal | | | | | | | | | | | | | | |
| | VFG 21 | EPDM | | | | | | | | | | | | | | |
| Pressure relieve system | | Bellows (Stainless steel, mat. No. 1.4571) | | | | | | | | | | | Diaphragm (EPDM) | | | |

¹⁾ Valves with built in flow divider for noise reduction (see accessories)

²⁾ At temperatures above 150 °C (DN 15-125)/140 °C (DN 150-250) only with seal pots (see Accessories)

³⁾ In steam applications always accessories have to be used - see table on page 2 below

Technical data (continuous)

Actuators

| Type | | AFD | | | | | | | |
|--|--|-------|------|-----|--------|------|----------|---------|-----------|
| Actuator size | cm ² | 32 | 80 | 160 | 250 | 630 | | | |
| Max. operating pressure | bar | 25 | 25 | 25 | 25 | 16 | | | |
| Diff. pressure setting ranges and spring colours | bar | black | red | red | yellow | blue | red | yellow | yellow |
| | | 8-16 | 3-12 | 1-6 | 0,5-3 | 1-6 | 0,15-1,5 | 0,1-0,7 | 0,05-0,35 |
| Materials | | | | | | | | | |
| Actuator housing | Stainless steel, mat. No. 1.0338, zinc plated and yellow chromate | | | | | | | | |
| Control diaphragm | EPDM (Rolling; fibre enforced) | | | | | | | | |
| Impulse tube | Stainless steel tube Ø10 × 0,8 mm copper tube Ø10 × 1 mm, threaded fitting G ¼, ISO 228 | | | | | | | | |

Application principles

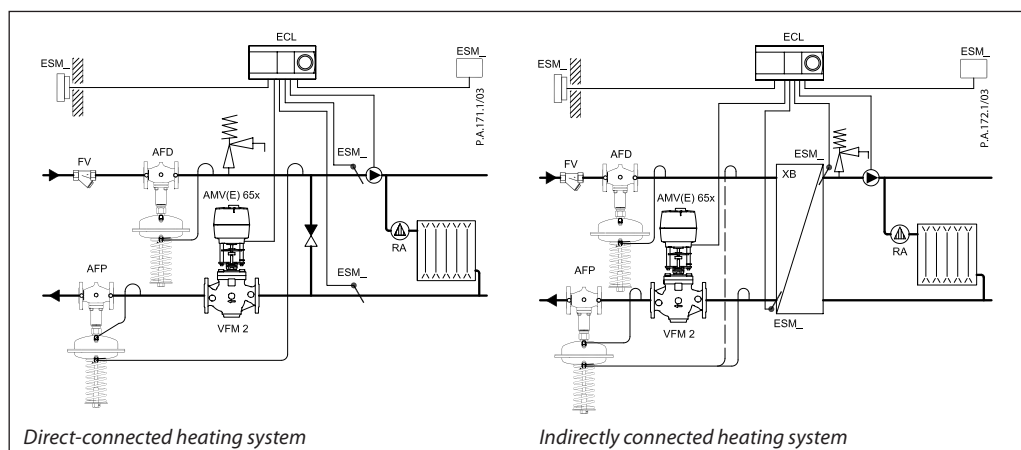

Combinations

Example
Pressure reduction and temperature controller AFD / AFT06 / VFG 2;
 k_{VS} 4,0; DN 15; PN 16; T_{max} 150 °C;
0,15-1,5 bar; range 20 ... 90 °C

- 1x VFG 2 DN 15 valve
Code no: **065B2388**
- 1x AFD actuator
Code no: **003G1005**
- 1x AFT06 thermostat
Code no: **065-4391**
- 1x Combination piece KF2
Code no: **003G1398**
- 1x Impulse tube set AF
Code no: **003G1391**

Parts will be delivered separately.

Note:
For AFT 06 and STFW thermostat data see relevant data sheet

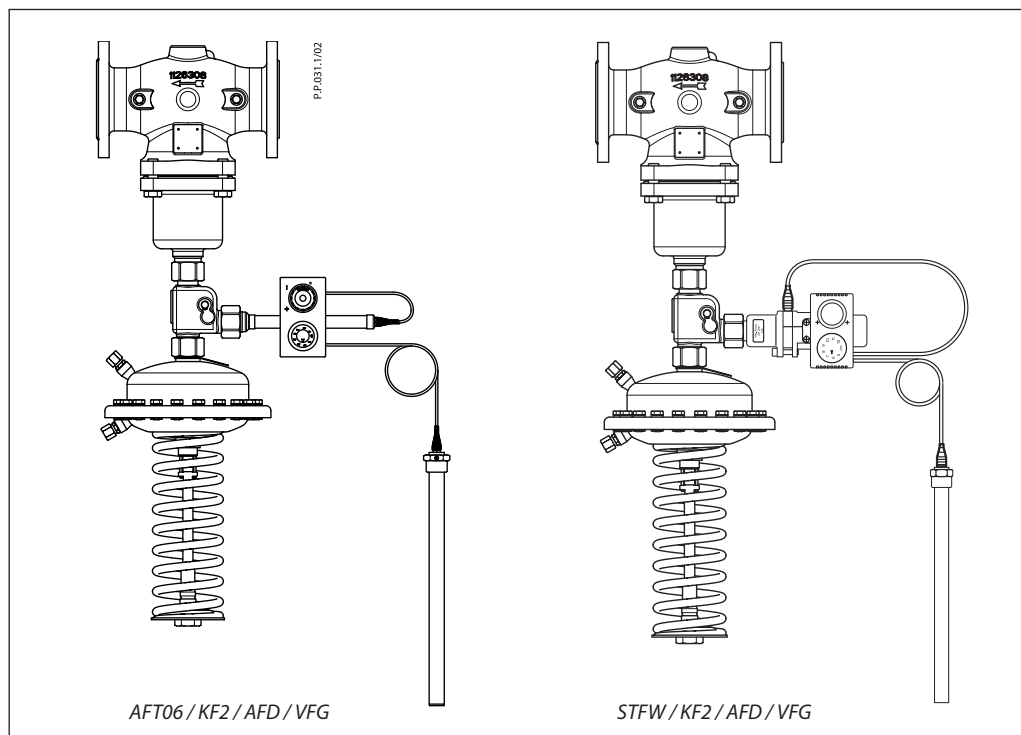

Installation position

DN 15-80 $T_{max} \leq 120\text{ }^{\circ}\text{C}$

DN 15-80 $T_{max} > 120\text{ }^{\circ}\text{C}$; DN 100-250

The controllers can be installed in any position.

The controllers can be installed in horizontal pipes only, with a pressure actuator oriented downwards.

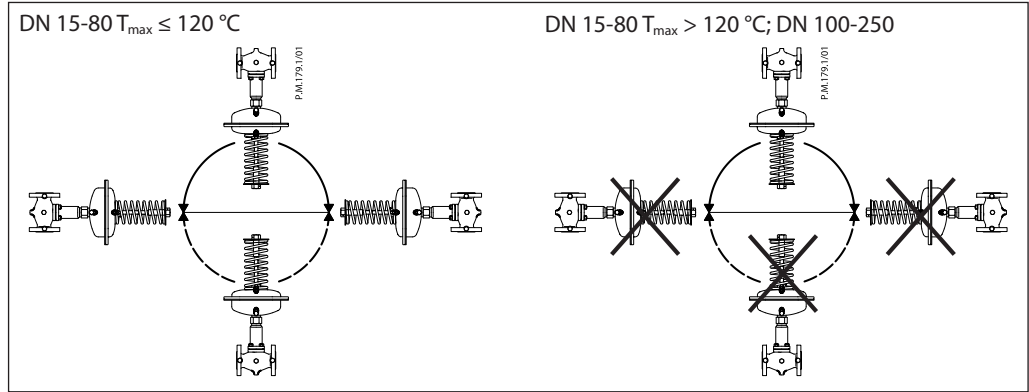

Pressure temperature diagram

Working area is below P-T line and it ends at T_{max} for each valve

Note:

- ① at temperatures above 150 °C (DN 15-125) / 140 °C (DN 150-250) only with seal pots (see Accessories)
- ② In steam applications always accessories have to be used - see table on page 2 below

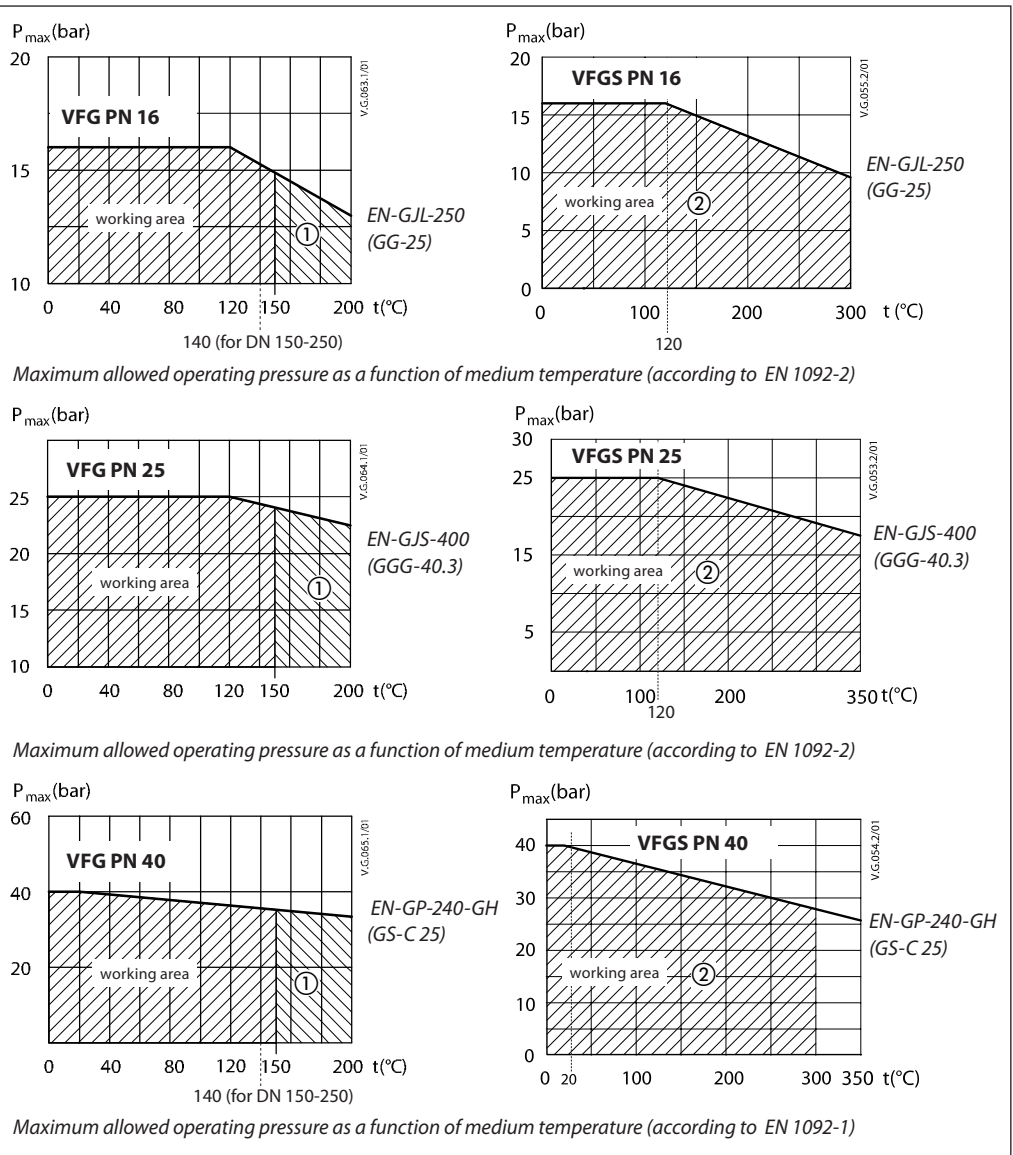

Sizing - water

Pressure reduction controller has to control 6,0 bar behind the controller. Max. flow through the system is less than 4,0 m³/h, min. flow pressure is 7,5 bar.

k_v value is calculated according to formula:

$$k_v = \frac{Q_{max}}{\sqrt{\Delta p_{AFD}}} = \frac{4,0}{\sqrt{1,5}}$$

$$k_v = 3,3 \text{ m}^3/\text{h}$$

Given data:

$$Q_{max} = 4,0 \text{ m}^3/\text{h}$$

$$p_{1 \text{ min}} = 7,5 \text{ bar}$$

$$p_{reduced} = 6,0 \text{ bar}$$

Solution:

The example selects AFD DN 15, k_{vS} value 4,0, with pressure setting range 0,15-1,5 bar

Nominal pressure PN 25

The min. differential pressure across the controller is calculated from the formula:

$$\Delta p_{AFD} = p_{1 \text{ min}} - p_{reduced} = 7,5 - 6,0$$

$$\Delta p_{AFD} = 1,5 \text{ bar}$$

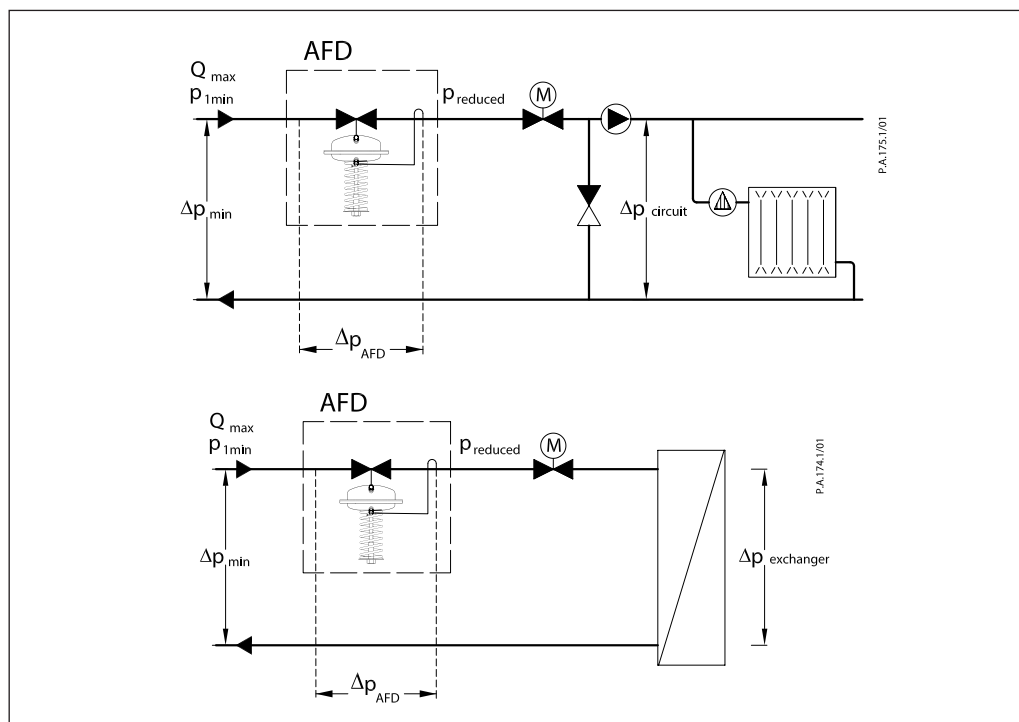

Sizing - steam

Max. Δp in low pressure steam application variance from 0.5 bar to 6 bar (see page 2)

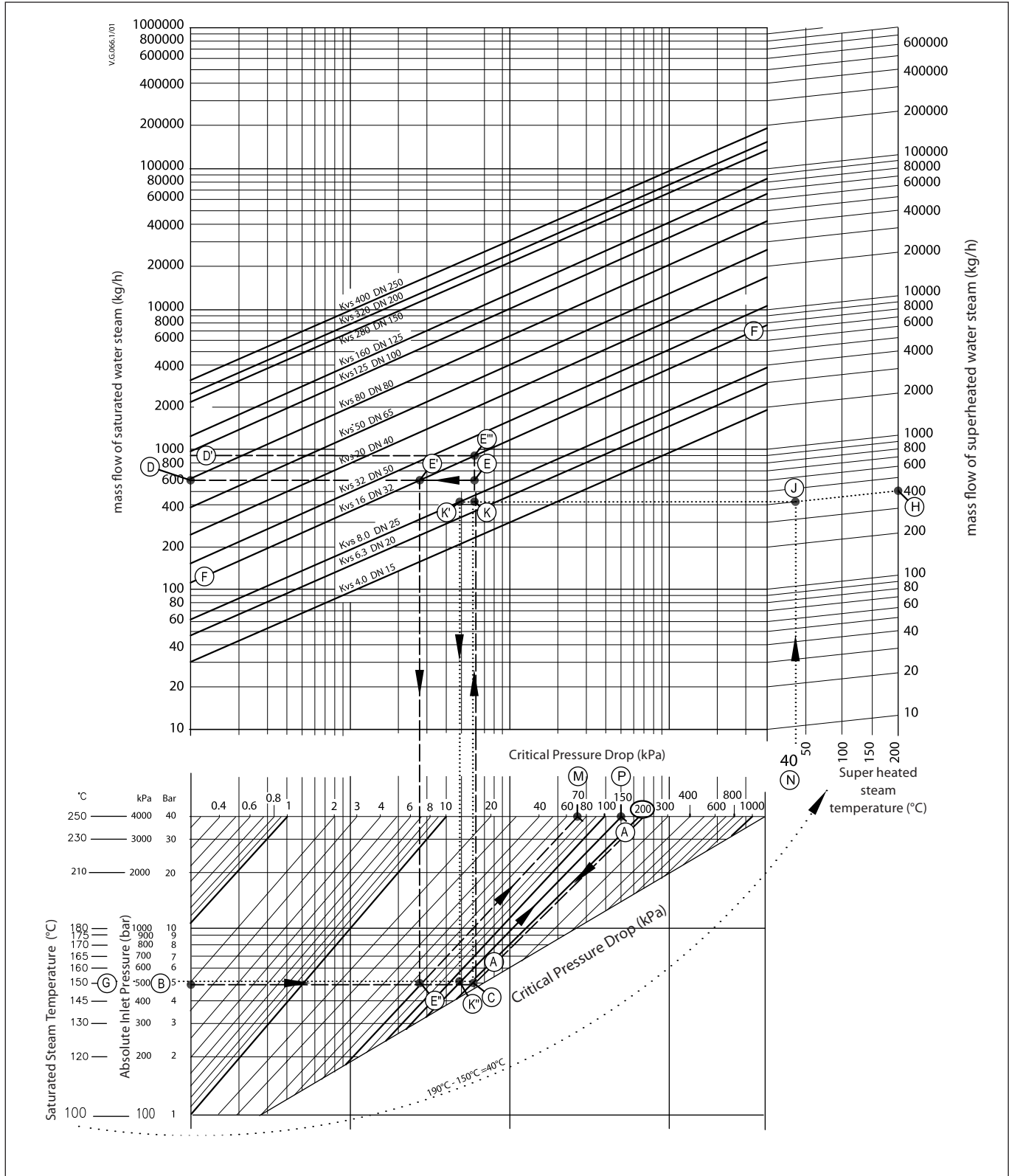

Steam valve sizing is based on 40 % of the absolute steam pressure (immediately upstream of the valve) being dropped across the valve when fully open. At this condition the steam is travelling at or close to its critical velocity

(approx. 300 m/s) and throttling will occur over the full valve stroke. If the steam is travelling slower than this then the first part of the valve stroke will merely increase the velocity of the steam without reducing the volumetric flow.

Control valve sizing diagram for steam
(continued)
1 For saturated steam
Design data:

Flow rate: 600 kg/h

Absolute inlet pressure: 5 bar (500 kPa)

- follow dashed line -

The absolute inlet pressure is 500 kPa. 40% of this is 200 kPa.

Locate the diagonal line corresponding to the pressure drop of 200 kPa (line A-A).

Read the absolute inlet pressure on the lower left hand scale (point B), and draw a horizontal line across until it meets the pressure drop diagonal (A-A) at point C.

From this point extend a vertical line upwards until it meets the horizontal line representing the steam flow of 600 kg/h from point D. The intersection of this is point E.

The nearest diagonal kvs line above this is line F-F with a k_{vs} 16 (point E'). If the ideal valve size is not available the next largest size should be selected to ensure design flow.

The pressure drop through valve at the flow rate is found by the intersection of the 600 kg/h line with F-F (point E') and dropping a vertical; this actually hits the horizontal line for 500 kPa (point E'') inlet pressure at a pressure drop diagonal of 70 kPa (point M). This is only 14 % of the inlet pressure and the control quality will not be good until the valve has partially closed. As with all steam valves this compromise is necessary since the next smaller valve would not pass the required flow (maximum flow would have been about 480 kg/h).

The maximum flow for same inlet pressure is found by extending the vertical line (C-E) through point E until it crosses the k_{vs} 16 line F-F (point E''') and reading off the flow 900 kg/h (point D').

Solution:

The example selects AFD DN 32, k_{vs} value 16, with pressure setting range 0,15-1,5 bar

2 For superheated steam
Design data:

Flow rate: 400 kg/h

Absolute inlet pressure: 5 bar (500 kPa)

Steam temperature: 190 °C

The procedure for superheated steam is much the same as for saturated steam, but uses a different flow scale which slightly elevates the readings according to the degree of superheat.

- follow dotted line -

As before, the diagonal pressure drop line A-A is located as before for 40 % of 500 (200 kg/h). The horizontal inlet pressure line through point B is now extended to the left to read off the corresponding saturated steam temperature at point G (150 °C). The difference between the saturated steam temperature and the superheated steam temperature is 190 °C - 150 °C = 40 °C (point N).

The superheated steam flow is found on the upper right hand scale, point H, and the diagonal line is followed down from here until it meets a vertical line from the steam temperature elevation (40 °C) at point J.

As before, the horizontal line through point B is drawn to cut line A-A at point C and the point where the vertical line from this point meets the horizontal line from point J is the operating point (point K). This horizontal line, J-K, is the corrected flow line. The nearest diagonal line above this is for k_{vs} 8 (point K'). A vertical line dropped from the intersection of J-K with the k_{vs} 8 line intersects the 500 kPa inlet pressure line (point K'') at a pressure drop diagonal of about 150 kPa (point P). This is about 30% of the inlet pressure which will give reasonable control quality (compared to recommended ratio of 40%).

Solution:

The example selects AFD DN 25, k_{vs} value 8, with pressure setting range 0,15-1,5 bar

Design

1. Valve body
2. Cover
3. Valve seat
4. Valve insert
5. Pressure relieved valve cone
6. Valve stem
7. Bellows for pressure relief of valve cone
8. Actuator
9. Diaphragm for pressure relief of valve cone
10. Control diaphragm for differential pressure control
11. Setting spring for diff. pressure control
12. Adjuster for diff. pressure setting, prepared for sealing
13. Stuffing cone
14. Union nut
15. Compression fitting for impulse tube
16. Upper casing of diaphragm
17. Lower casing of diaphragm
18. Air space bore
19. Valve body extension
20. Shut off valve for water filling
21. Closing plug

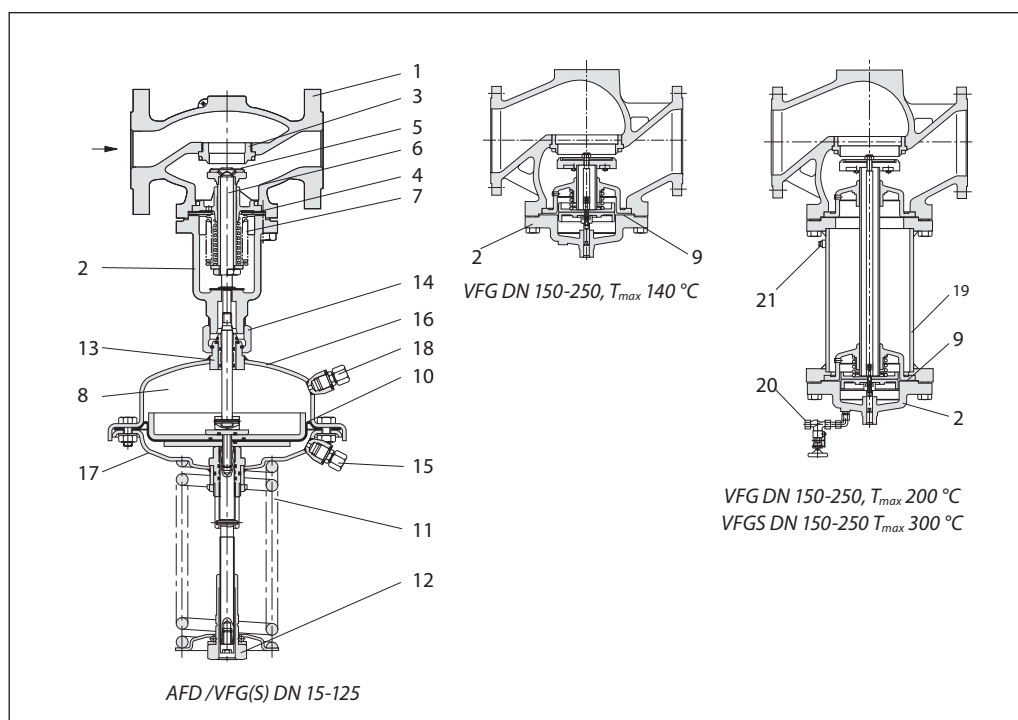

Function

The pressure behind of the control valve is being transferred through the impulse tube to the actuator chamber and act on control diaphragm for differential pressure control. On the other side of the diaphragm atmospheric pressure is acting (through air space bore). Control valve is normally opened. It closes on rising pressure and opens on falling pressure to maintain constant pressure.

Settings

Pressure setting
 Differential pressure setting is being done by the adjustment of the setting spring for diff. pressure control. The adjustment can be done by means of spring for diff. pressure setting and pressure indicators.

Dimensions

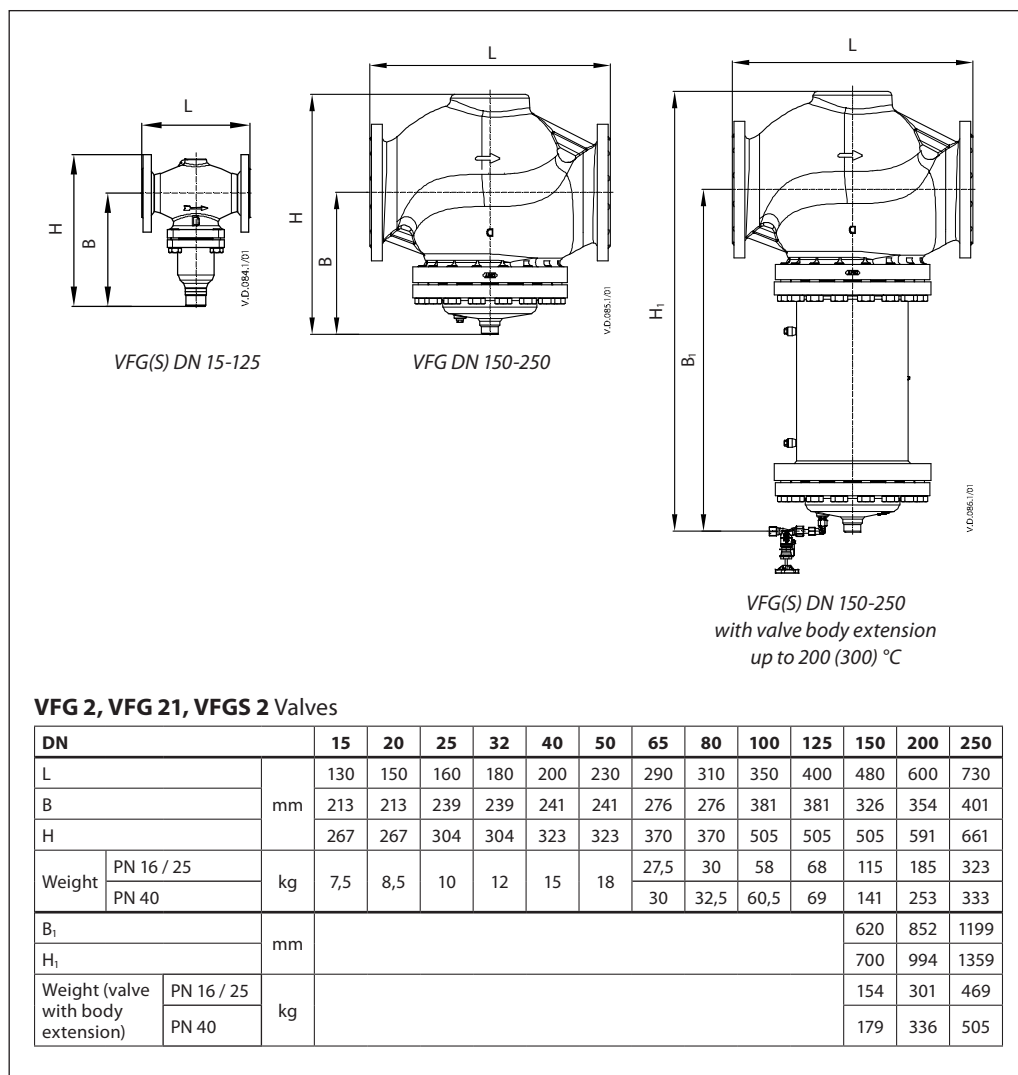

Dimensions (continuous)

